

Yard Ramp Portable Steel Ramp

VERSATILE DESIGN FOR YOUR YARD RAMP REQUIREMENTS

IDEAL FOR:

- Dock to grade applications
- Loading and unloading freight carriers
- Loading and unloading rail cars
- New construction sites
- Temporary shipping yards or mounted stationary positions



A Division of Systems, LLC



The Tow Clamp connects between the ramp pocket and the tow hitch of your fork truck and permits easy transportation of the lift over longer distances.

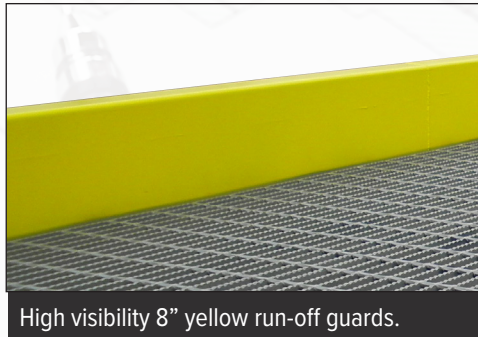

High visibility 8" yellow run-off guards.



Hydraulic adjustment
able height adjustmen
virtually any trailer bec
raised height of 36' ur



A 60" transition at grade and 30" transition at dock height is constructed of high strength diamond tread plate beveled and recessed for smooth transition onto and off the yard ramp.



The Fork Clamp permits easy positioning of the ramp over short distances. Fork clamp inserts into the ramp pocket and clamps onto the fork blade.

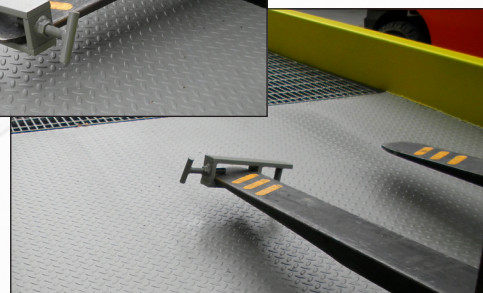

Serrated bar grating
tion. The open web de
debris, rain, snow, oil

Yard Ramp Portable Steel Ramp

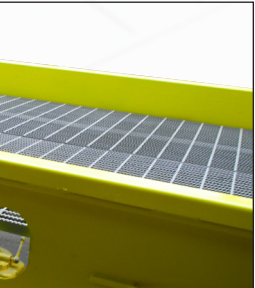

system permits fast re-
t of the yard ramp with
d height. Note: maximum
it is 70" and 30' is 80".



72" long level-off section is standard on all 36' long units to permit easy access for end-loads and added mobility of lift trucks. Note: Longer level-off sections are available for custom applications. The shorter 30' ramp is ideal for ground to dock access applications where level-off is not required.



15" lip section provides for a smooth transition on and off the carrier bed.

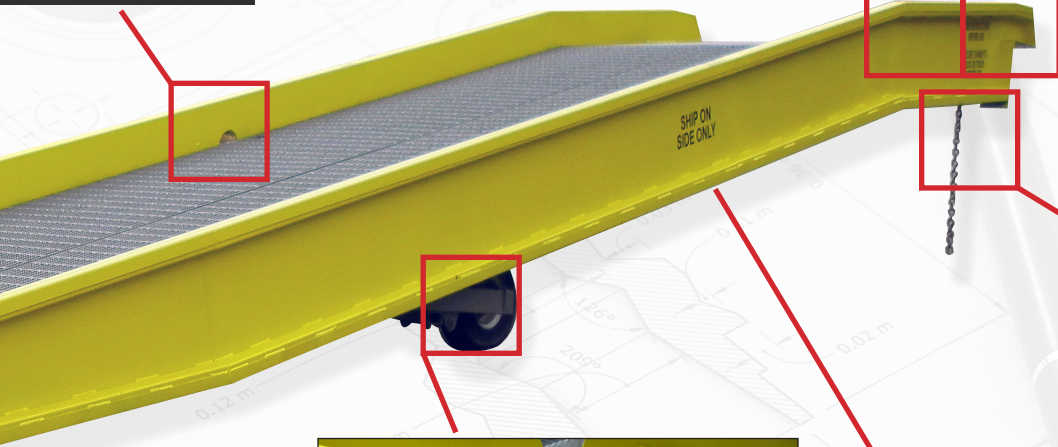

Safety chains hold the ramp tight to the carrier and assure adequate lip purchase is maintained with the carrier bed.

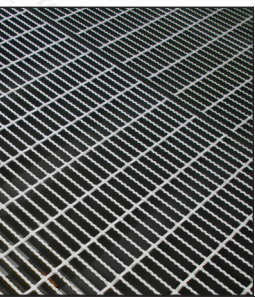

provides excellent trac-
design prevents build up of
and grease.



Heavy-duty axle assembly with 18" industrial solid rubber tires adds a high level of mobility to the yard ramp for easy positioning. Note: axle assembly can be removed or raised for permanent dock ramp installations.



Structure consists of heavy duty formed steel side girders fully welded to high strength steel joists. (Picture shows under side of ramp)



Yard Ramp

Portable Steel Ramp

Yard Ramp Options

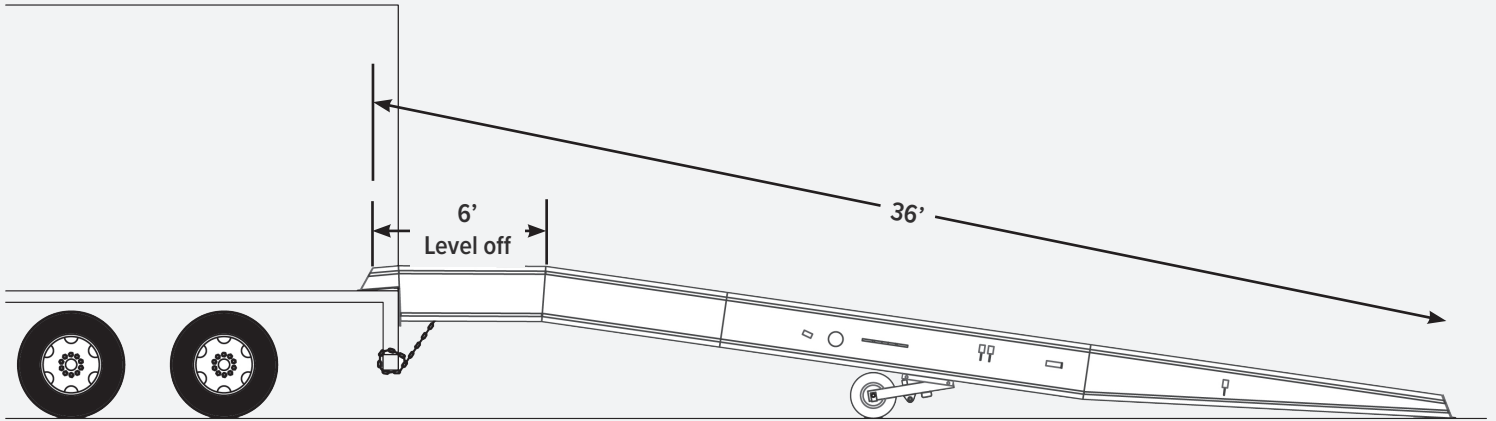

Note: 48-52" typical truck bed equals ramp grade of $\pm 14\%$

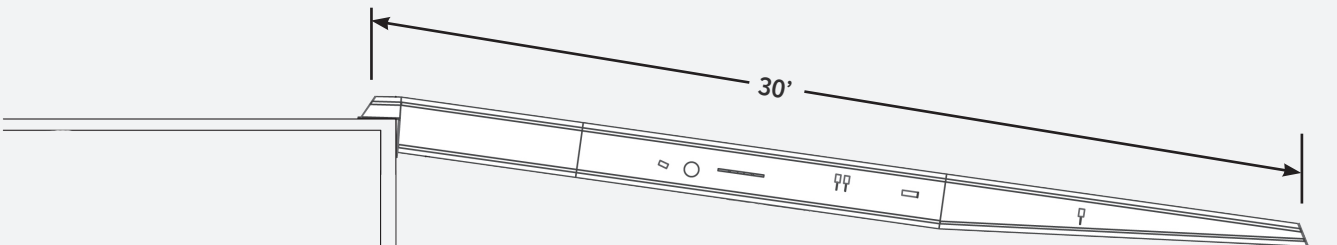

Model	Overall Width	Inside Width	Length	Lip Section	Capacity
YD 70 30	70"	64"	30'	15"	16,000 lbs
YD 84 30	84"	78"	30'	15"	20,000 lbs
YD 70 36	70"	64"	36'	15"	25,000 lbs
YD 84 36	84"	78"	36'	15"	30,000 lbs
Other Size					
Custom length and width are available.					
* Note 36' units include 6' level-off section					

W194N11481 McCormick Dr. | Germantown, WI 53022
 poweramp.com | sales@poweramp.com
 800-643-5424



poweramp.com

YARD RAMP 12/2024

Designed, Engineered, and Manufactured in the U.S.A.
 © 2024 Systems, LLC/Poweramp
 Consistent with our policy of continuing product improvement, we reserve the right to change product specifications without notice or obligation.

